

LED – medium intensity obstruction light – AOL 304-2006 – A/W ES

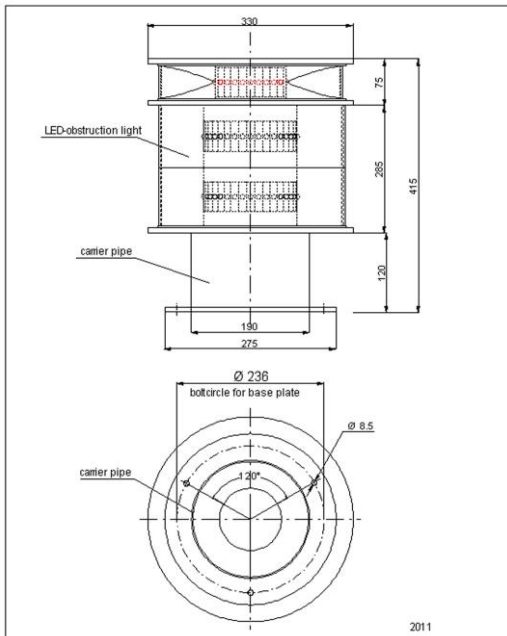

Technical data

Type	AOL 304-2006 – A/W ES
Lamp	LED-insert with high performance LED, white and red
Supply voltage	- 100-240V / AC 50/60Hz - 88-375V / DC - 21-27 / DC electronic ballast must be installed in external switch cabinet, power loss due to long cable run is regulated by electronic ballast
Power consumption	white approx. 60W / in the daytime, blinker beacon red approx. 8W / night operation, steady light
Luminous intensity	effective 20.000 cd white, ±25% photometric 170 - 255 cd red horizontal 360°
Flash rate	white: 1s on / 2s off red: 1s on / 0,5s off / 1s on / 1,5s off
Average service life	> 100.000 hours
Range of temperature	-40°C to +60°C
Housing	powder-coated aluminum, traffic white, stainless steel V4A available, colors according to RAL table
Optics	optical system
Electrical connection	switch cabinet: - dimension: 500x500x210mm - AE 1050.500 metal work - screw terminals up to 2,5mm ² - cable gland 1xM16, 1xM20, 2xM25 - main fuse 10A in switch cabinet
Fault indication	failure message via potential-free contacts
Degree of protection	IP 66 / obstruction light and switch cabinet
Dimensions	see dimension sketch
Weight	approx. 14 kg obstruction light approx. 22 kg switch cabinet
Mechanical stress	shock-proof, vibration-resistant
Specification	CE - certified, meets ICAO Annex14, table 6-3. medium intensity obstruction light type A und type W red ES, approved by the German Federal Ministry of Transport
Over-voltage protection	according to EN 61643-11:2001 in SPD type 2 for switch cabinet and obstruction light
Functions	brightness control available
Quality characteristics	- integrated heating system to avoid icing - high-efficient protection of LED luminous element against ultraviolet light, direct sunlight and condensation - well-proven system since 1999
Accessories	- twilight switch - GPS module



The required supply voltage has to be stated when ordering.

Bescheinigung

Hiermit wird bestätigt, dass die Laterne

Typ: EST 100ES/AOL 305ES

Hersteller: Hochspannung Lichttechnik
Bernd Ballaschk GmbH
Willischzaweg 48
D- 03096 Burg / Spreewald

den Anforderungen des Technischen Standards

„Erweiterte Spezifikationen für das Feuer W, rot zur Kennzeichnung von
Windenergieanlagen als Luftfahrthindernis -Feuer W, rot ES-“

(Fachstelle der WSV für Verkehrstechnik, Version 1 vom 26.02.2009)
entspricht.

Koblenz, den 19.04.2011



Streng