

## LED – medium intensity obstruction light – AOL 304-2006 – A/B

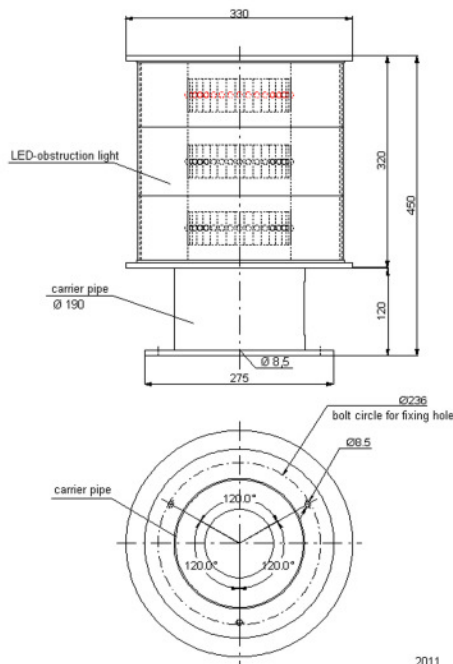

The required supply voltage has to be stated when ordering.

### Technical data

Type	AOL 304-2006 – A/B
Lamp	LED-insert with high performance LED, white and red
Supply voltage	- 100-240V / AC 50/60Hz - 88-375V / DC - 21-27 / DC electronic ballast must be installed in external switch cabinet, power loss due to long cable run is regulated by electronic ballast
Power consumption	white approx. 60W / in the daytime, blinker beacon red approx. 16W / night operation, blinker beacon
Luminous intensity effective	20.000 cd white, $\pm 25\%$ 2.000 cd red, $\pm 25\%$ horizontal 360°
Flash rate	1s on / 2s off
Average service life	> 100.000 hours
Range of temperature	-40°C to +60°C
Housing	powder-coated aluminum, traffic white, stainless steel V4A available, colors according to RAL table
Optics	optical system
Electrical connection	switch cabinet: - dimension: 500x500x210mm - AE 1050.500 metal work - screw terminals up to 2,5mm <sup>2</sup> - cable gland 1xM16, 1xM20, 2xM25 - main fuse 10A in switch cabinet
Fault indication	failure message via potential-free contacts
Degree of protection	IP 66 / obstruction light and switch cabinet
Dimensions	see dimension sketch
Weight	approx. 14 kg obstruction light approx. 22 kg switch cabinet
Mechanical stress	shock-proof, vibration-resistant
Specification	CE - certified, meets ICAO Annex14, table 6-3. medium intensity obstruction light type A und type B, approved by the German Federal Ministry of Transport
Over-voltage protection	according to EN 61643-11:2001 in SPD type 2 for switch cabinet and obstruction light
Functions	brightness control available
Quality characteristics	- integrated heating system to avoid icing - high-efficient protection of LED luminous element against ultraviolet light, direct sunlight and condensation - well-proven system since 1999
Accessories	- twilight switch - GPS module

Certified Translation from the German Language

WASSER- UND SCHIFFFAHRTSVERWALTUNG DES BUNDES (WSV)  
(German Federal Waterways and Navigation Administration)  
**Fachstelle des WSV fuer Verkehrstechniken**  
(Traffic Technology Center of WSV)  
at the Wasser- and Schifffahrtsamt Koblenz  
(Koblenz Office for Waterways and Navigation)

/LOGO/

**Certificate**

**pursuant to No. 24 of the German General Administrative Regulation  
for the Marking and Lighting of Obstacles to Air Navigation (AVV Kennzeichnung)  
to be presented at the competent regulatory authority in compliance with the Aviation Act**

Type of light: *White flashing light for daytime use*  
Manufacturer: Hochspannungs-Lichttechnik  
Willischzaweg 48  
D-03096 Burg/Spreewald (Germany)  
Classification: **AOL 304-2006 / EST 20000**

Based on the technical inspection by the *Fachstelle der Wasser- und Schifffahrtsverwaltung fuer Verkehrstechniken* (see letterhead for translation) conducted on 21 December 2006 it is herewith certified that the presented trial product sample of the type of lamp described above complies with the photometric requirements set out in *AVV Kennzeichnung* in the version of 02 September 2004 (BAnz (Federal Law Gazette) No. 168 dated 07 September 2004, p. 19 937; *Nachrichten fuer Luffahrer* I 4/05 of 06 January 2005).

Subject to any amendments in respect to the above requirements, this lamp type can be used to mark and light obstacles to air navigation.

Koblenz, this 15<sup>th</sup> day of January 2007

/OFFICIAL SEAL/

/German original signed/

(Strenge)

\*\*\*\*\*

I hereby certify that the above translation corresponds with the German copy presented to me.

Berlin, 20 August 2009

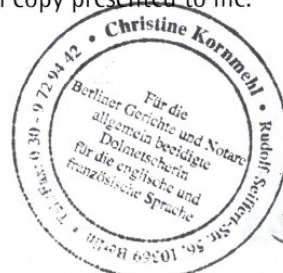

39-4

Certified Translation from the German Language

WASSER- UND SCHIFFFAHRTSVERWALTUNG DES BUNDES (WSV)

(German Federal Waterways and Navigation Administration)

**Fachstelle des WSV fuer Verkehrstechniken**

(Traffic Technology Center of WSV)

at the Wasser- and Schifffahrtsamt Koblenz

(Koblenz Office for Waterways and Navigation)

/LOGO/

**Certificate**

**pursuant to No. 24 of the German General Administrative Regulation**

**for the Marking and Lighting of Obstacles to Air Navigation (AVV Kennzeichnung)**

**to be presented at the competent regulatory authority in compliance with the Aviation Act**

Type of light: *Hazard beacon*

Manufacturer: Hochspannungs-Lichttechnik  
 Willischzaweg 48  
 D-03096 Burg/Spreewald (Germany)

Classification: **AOL 303-2006 / EST 2006**

Based on the technical inspection by the *Fachstelle der Wasser- und Schifffahrtsverwaltung fuer Verkehrstechniken* (see letterhead for translation) conducted on 12 June 2006 it is herewith certified that the presented trial product sample of the type of lamp described above complies with the photometric requirements set out in *AVV Kennzeichnung* in the version of 02 September 2004 (BAnz (Federal Law Gazette) No. 168 dated 07 September 2004, p. 19 937; *Nachrichten fuer Luftfahrer* I 4/05 of 06 January 2005).

Subject to any amendments in respect to the above requirements, this lamp type can be used to mark and light obstacles to air navigation.

Koblenz, this 19<sup>th</sup> day of June 2006

/German original signed/

(Strenge)

/OFFICIAL SEAL/

\*\*\*\*\*

I hereby certify that the above translation corresponds with the German copy presented to me.

Berlin, 20 August 2009

